



Form Travellers

Contents

1

General

2

Overhead Form
Traveller system

3

Underslung Form
Traveller system

4

Wing Form
Traveller system

5

Arch Form
Traveller system

6

Project gallery

7

Safety and quality

8

Services

1

General



General

Our modern Form Traveller (FT) system is a competitive and reliable solution.

With our 30 years of experience in conception and designing bridgebuilding equipment, we currently offer the market an economical and versatile formwork solution for the in-situ casting of bridge and viaduct deck segments.

Both the overhead and underslung Form Traveller (FT) systems have been designed to be used in building pre-stressed reinforced concrete decks build with the cantilever method, whether suspended or not by stays.

Form Travellers for casting arch segments in concrete, or deck wings also in concrete, round out our Form Traveller solutions.

Overhead Form Traveller system

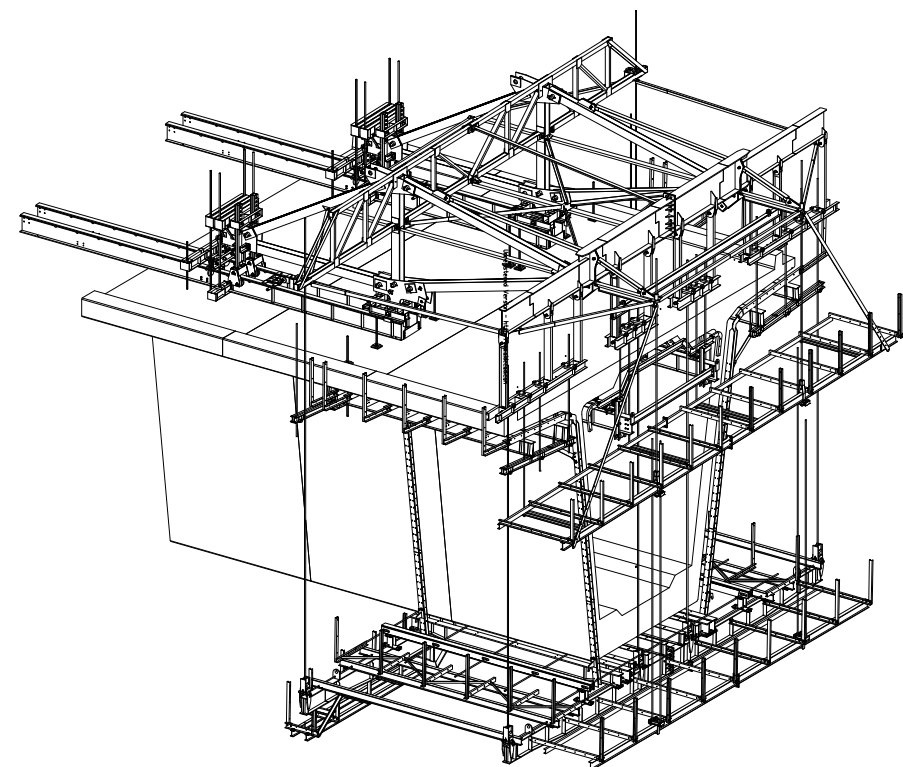

Underslung Form Traveller system

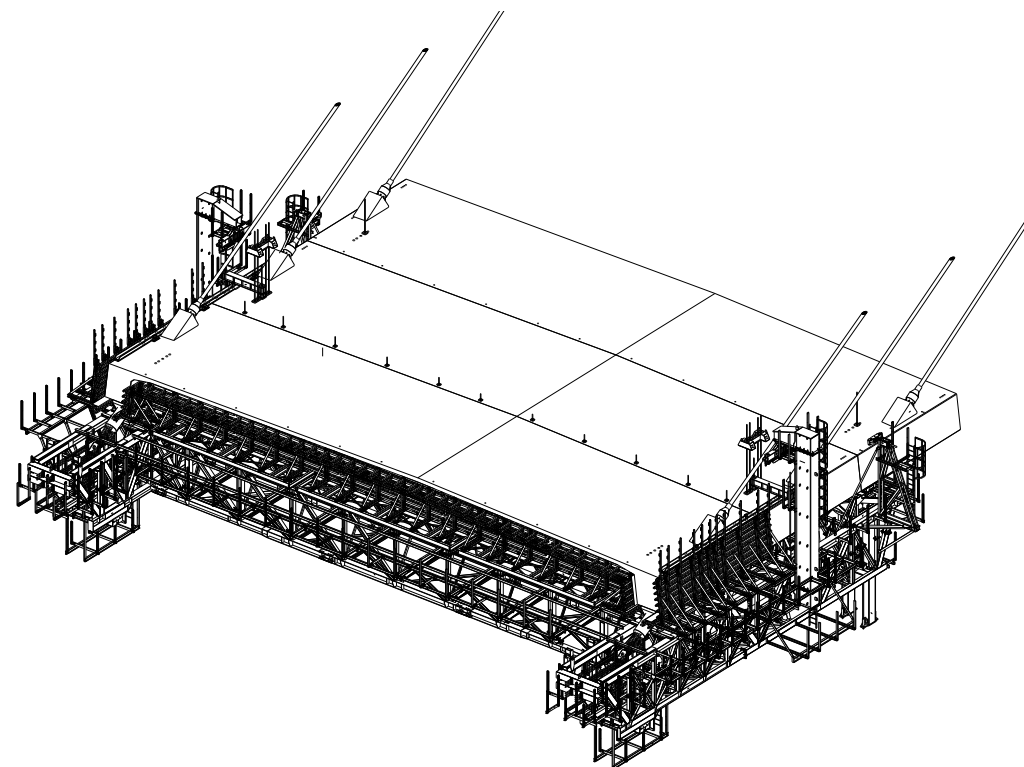

Wing Form Traveller system

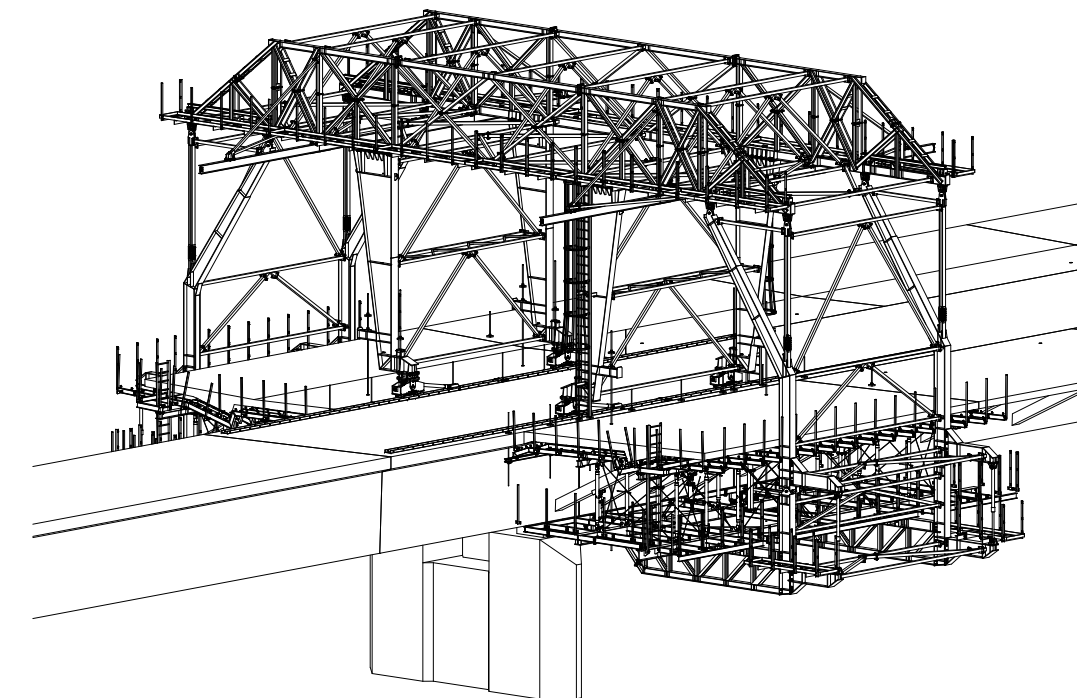

Arch Form Traveller system

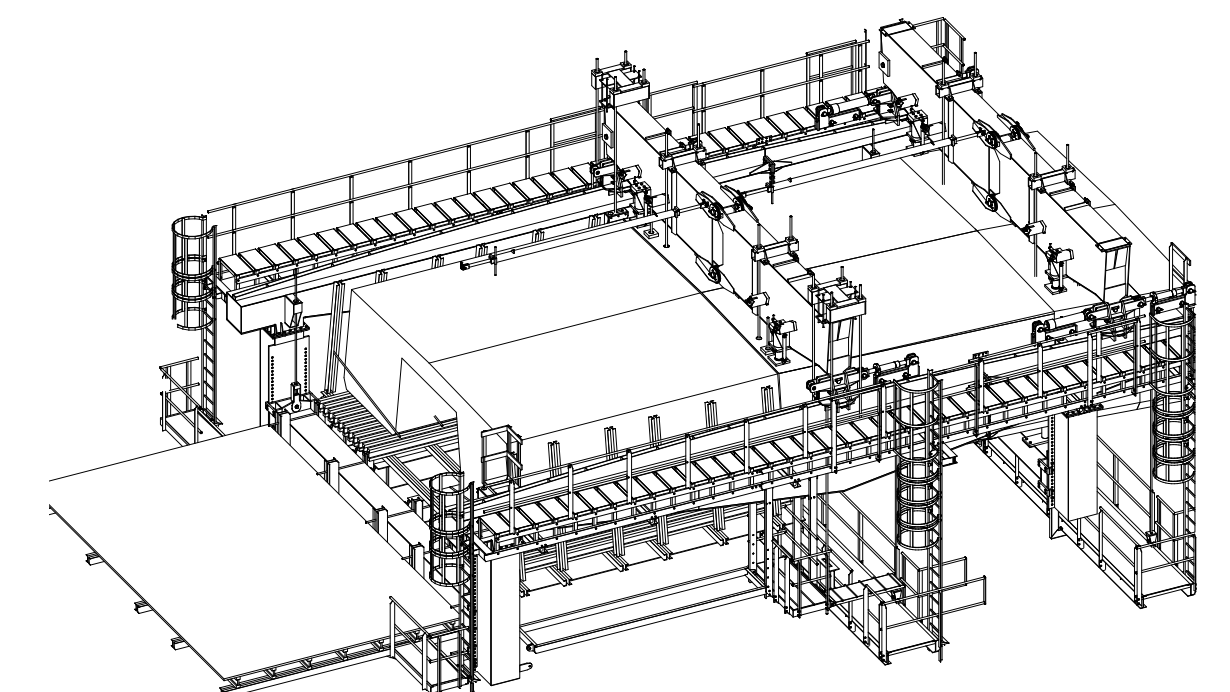

2

Overhead Form Traveller system





Overhead Form Traveller system

The Overhead Form Traveller system is the solution most commonly used for casting bridge and viaduct decks built with the cantilever method whose span varies from around 60 to 250 metres in length.

A standard Overhead Form Traveller is normally designed to be used in casting segments up to 5 metres in length and up to around 300 tons in weight.

For longer or heavier segments, “tailor-made” Form Travellers can always be designed to work in these special conditions.

Because of our extensive design experience, we can find the perfect solution for all different segments geometries.



Main components

A typical Overhead Form Traveller (FT) consists of a main self-supporting structure and a launching system combined with a specific formwork.

Main components:

- ① Front beam
- ② Rear truss
- ③ Transverse beams
- ④ Front bogie
- ⑤ External formwork
- ⑥ Internal formwork
- ⑦ Threaded bars
- ⑧ Bottom slab platform
- ⑨ Rear bogie
- ⑩ Wind bracing
- ⑪ Main rails
- ⑫ Main frame
- ⑬ Upper working platform
- ⑭ Lower working platform
- ⑮ Rear working platform

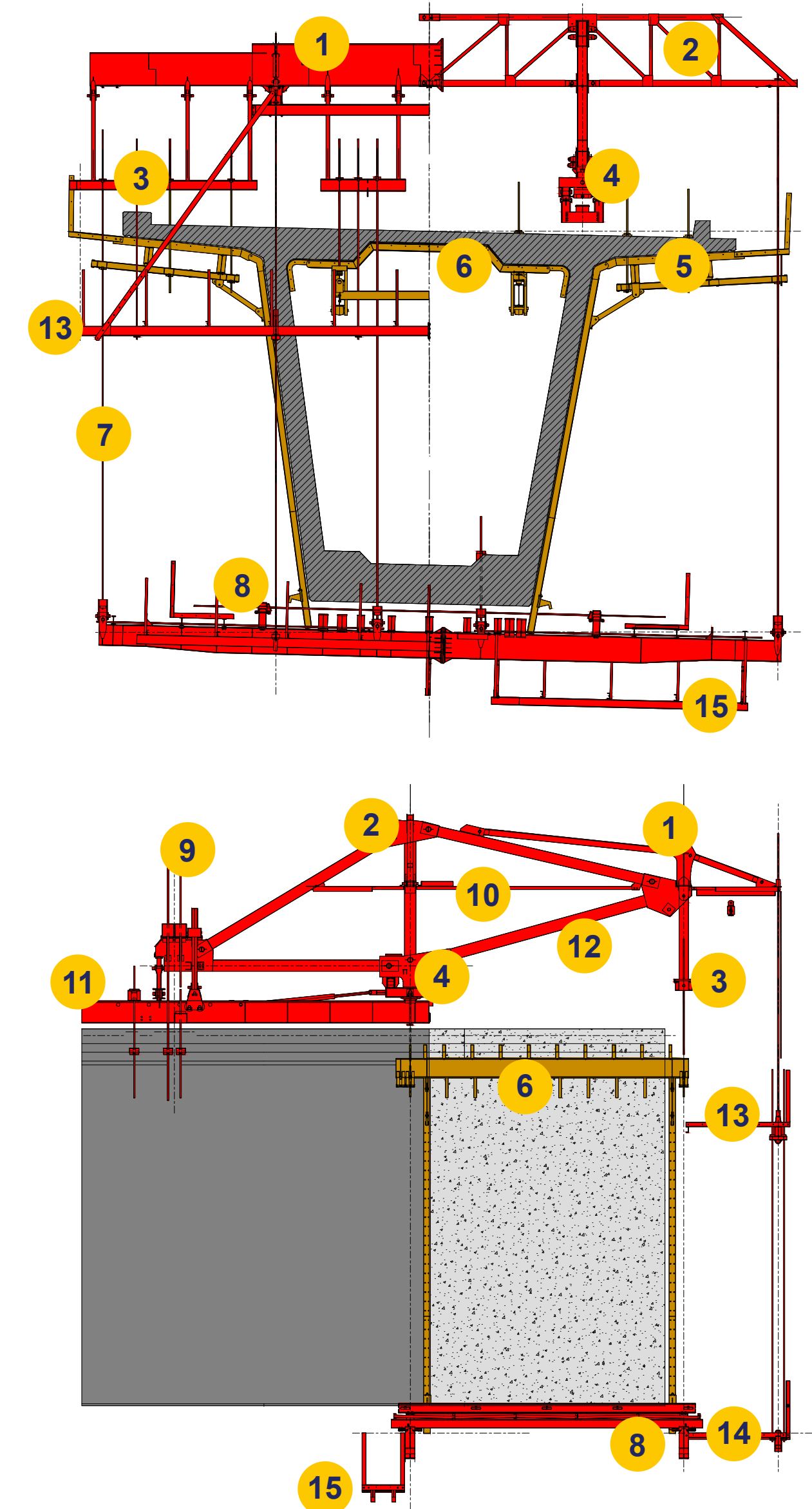

Formwork

The typical formwork of a Strukturas Form Traveller is comprised of a steel structure supplemented by saw wooden beams.

Beams such as H20 and others can be used instead of saw wooden beams, especially in external formwork where the beams of the web formwork's panels do not need to be sawn to adjust to the height, since they pass through the bottom slab platform of the Form Traveller (FT).

Strukturas' Form Traveller design includes also the wooden components design.

Main advantages:

Internal formwork is easily adjustable to the varying height of the section

Easily adaptable to future sections of other decks

Economical solution

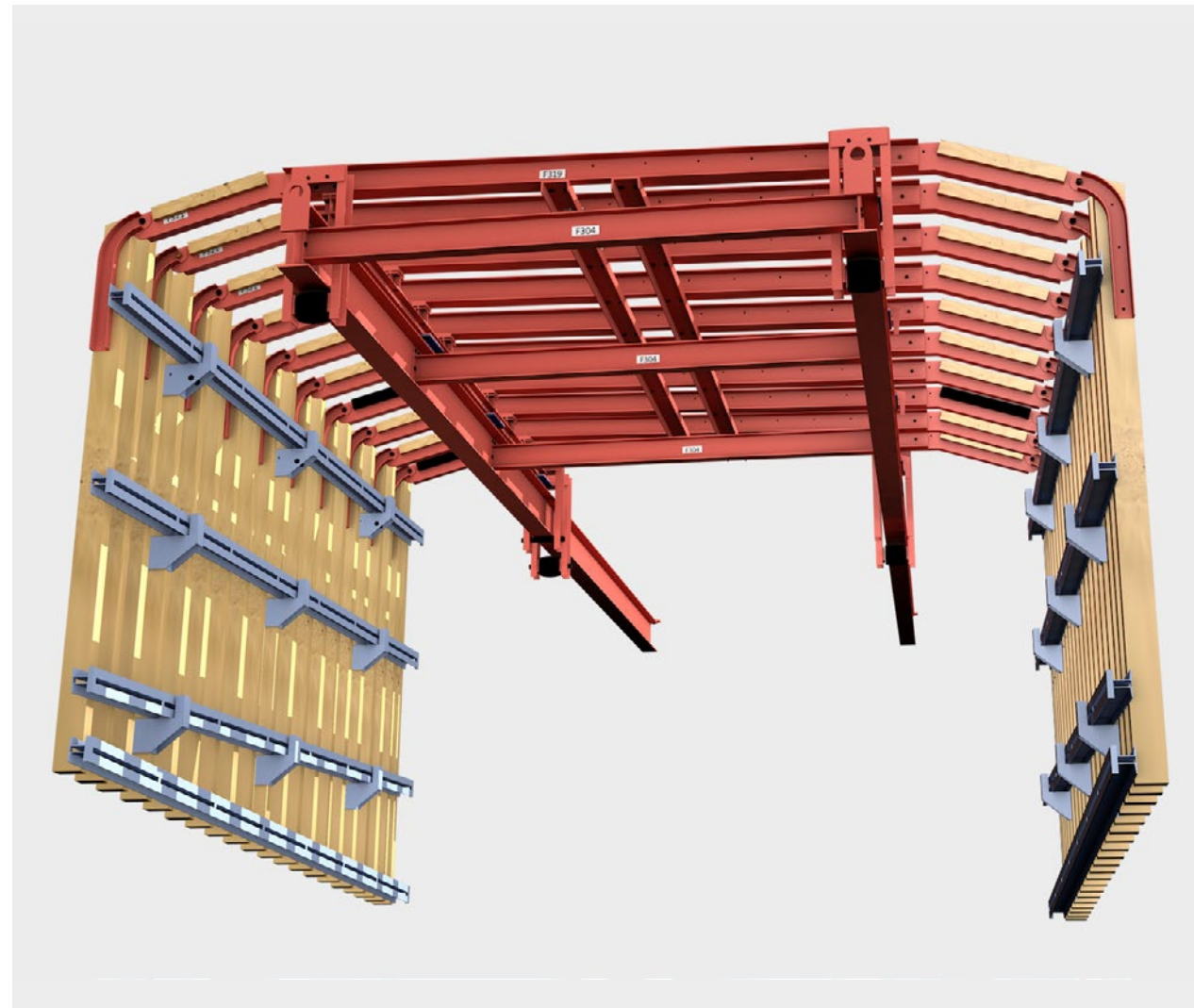

Internal formwork

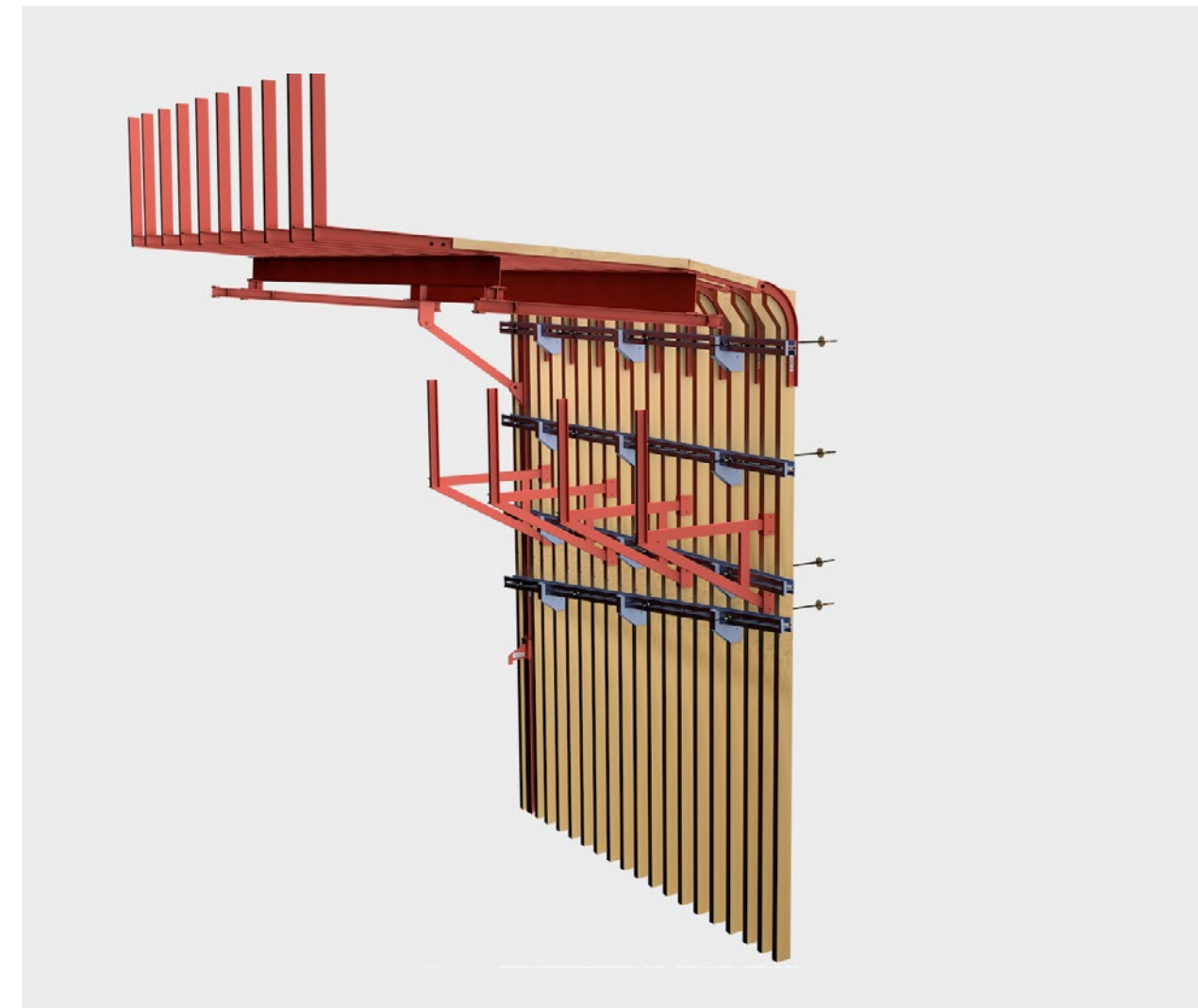

External formwork



Internal formwork – vertical saw wooden beams and horizontal saw wooden beams acting as strongbacks



External formwork– vertical saw wooden beams and horizontal steel beams acting as strongbacks



Internal formwork

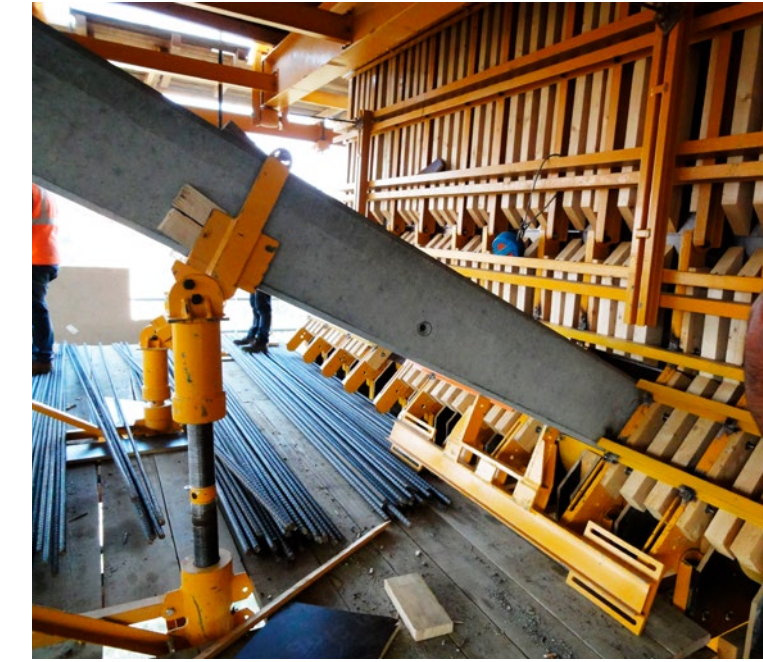

External formwork



In many special projects, the internal and external formwork includes devices tailored to these specific situations to ensure the Form Travellers' high level of performance, minimizing cycles,

auxiliary equipment and the amount of manpower needed for their operation.



Assembly over hammerhead

The Cross-Support Concept

The hammerhead of a deck built with the cantilever method must be at least 12 metres long in order to assemble the pair's Form Travellers simultaneously.

The auxiliary structure, called Cross-Support (CS), helps to minimize the hammerhead's length, thereby making its construction less complex and costly.

Main stages:

- ① Form Traveller ready to cast 1st segment
- ② Rail and auxiliary bogies installed
- ③ Cross-Support central structure dismantled
- ④ Left Form Traveller main frame rear part installed
- ⑤ Launch left Form Traveller after its auxiliary bogie is dismantled
- ⑥ Right Form Traveller main frame rear part installed
- ⑦ Launch right Form Traveller after its auxiliary bogie is dismantled
- ⑧ Dismantle auxiliary rail

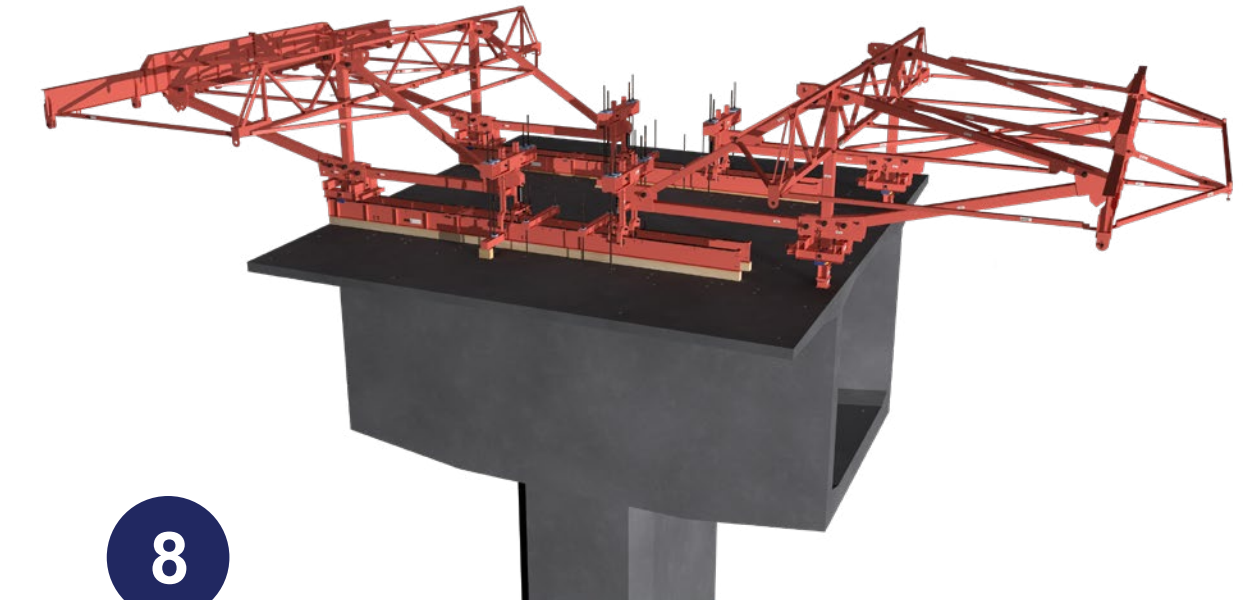
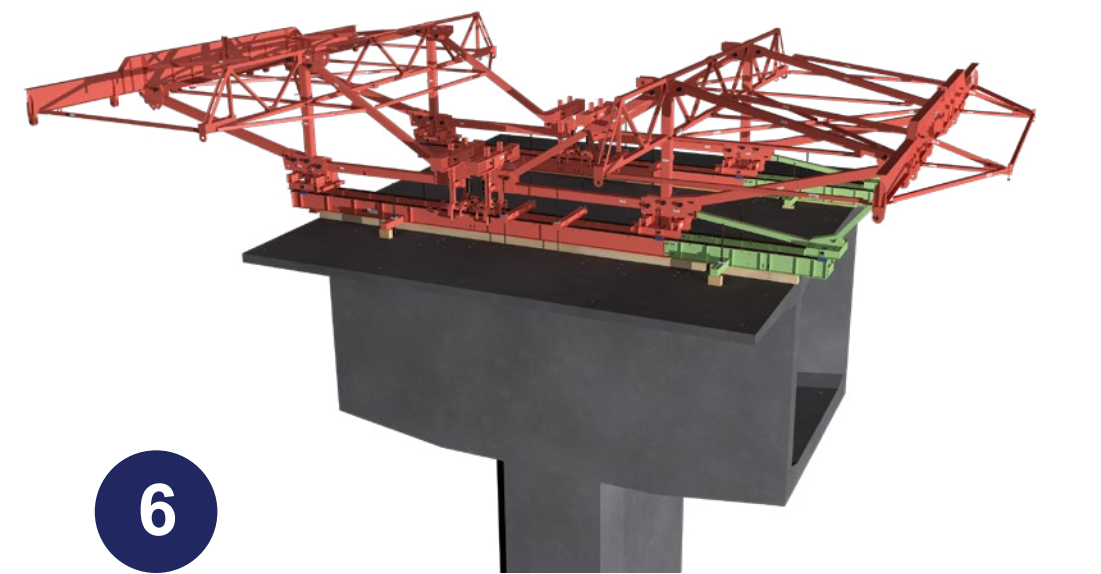
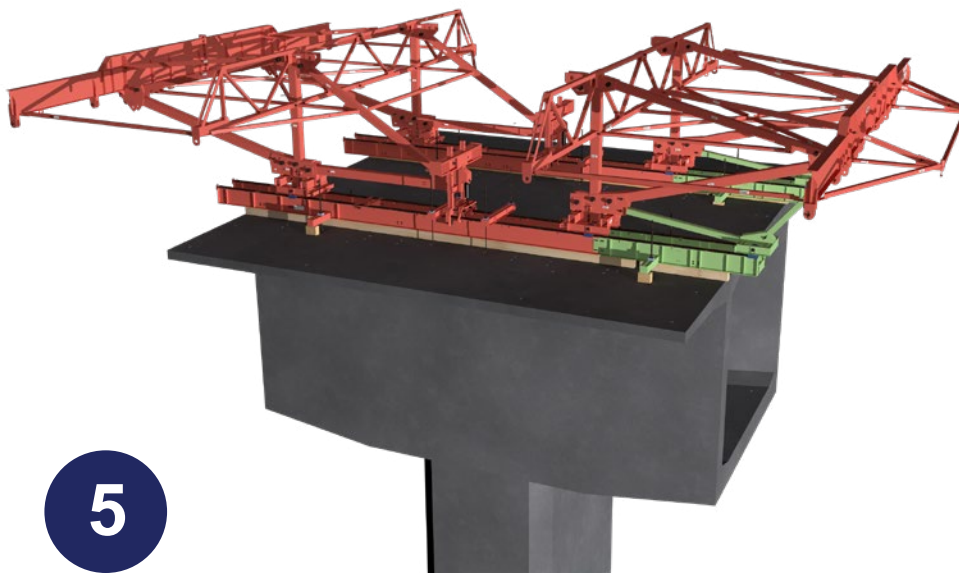
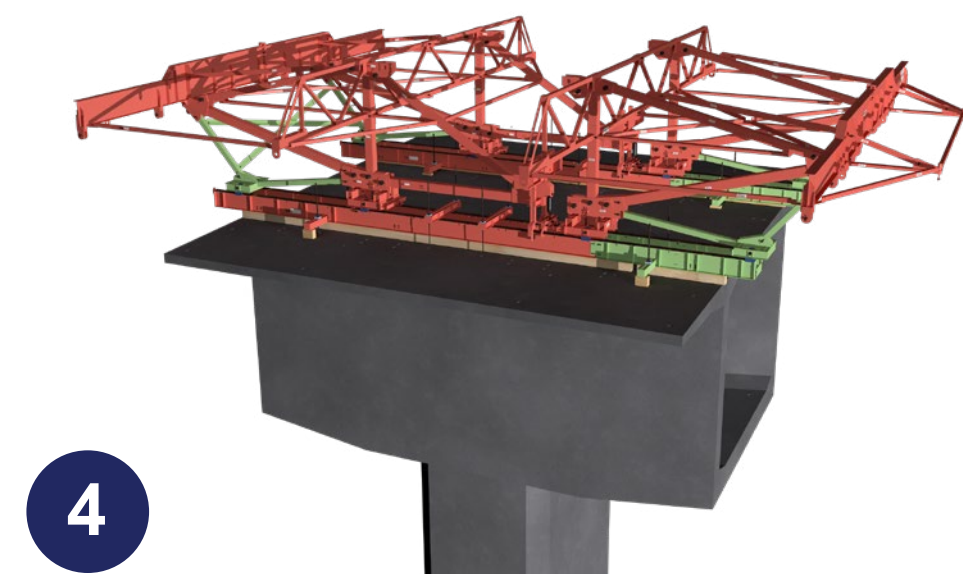
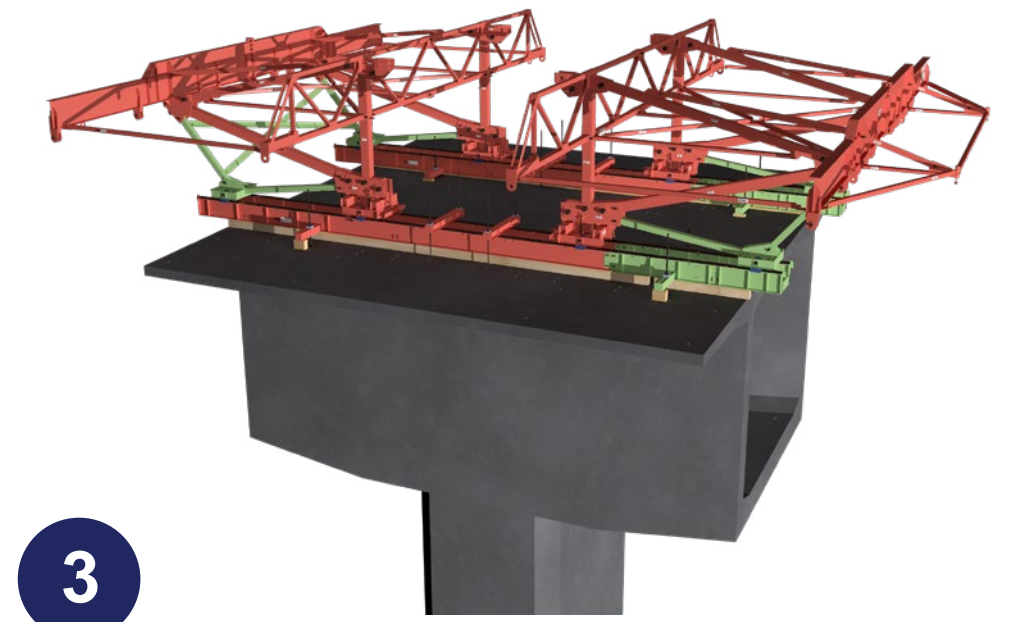
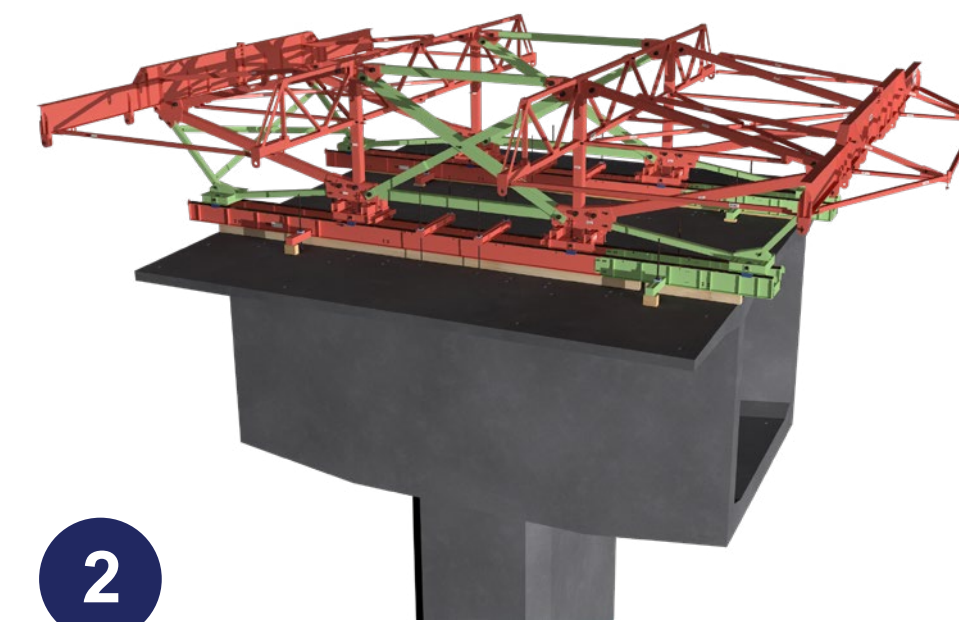
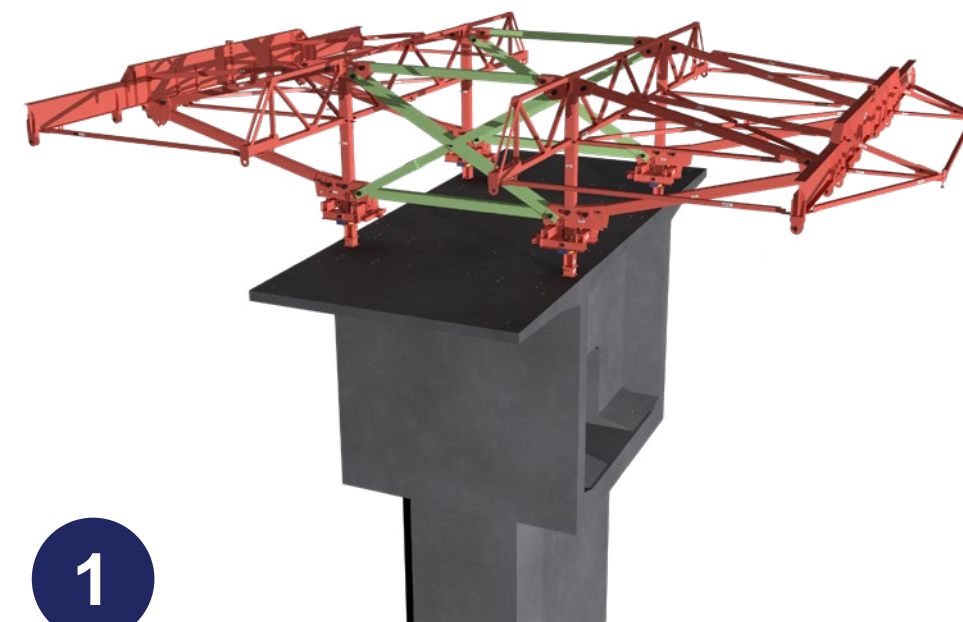

Assembly over hammerhead

Non-symmetrical casting

In many cases, non-symmetrical casting of the first segment can be the solution as an alternative to Cross-Support.

The use of this method corresponds to the initial assembly of only one Form Traveller (FT) and casting of the corresponding segment. This Form Traveller (FT) is then moved to the end of the cast segment, and the pair's second Form Traveller (FT) is assembled. The pair's second segment is then cast.

Subsequent segments will be cast symmetrically.



Launchback system

The use of the singular optional launchback system allows the Form Traveller (FT) to be disassembled close to the hammerhead, after being used in casting the deck's last segment.

This procedure streamlines operation and minimizes cost.



Bottom slab platform lifting system

The lifting of the bottom slab platform from the level of the foundation where it was fully assembled, using the optional lifting system, allows the Form Traveller (FT) to be installed quickly and safely.

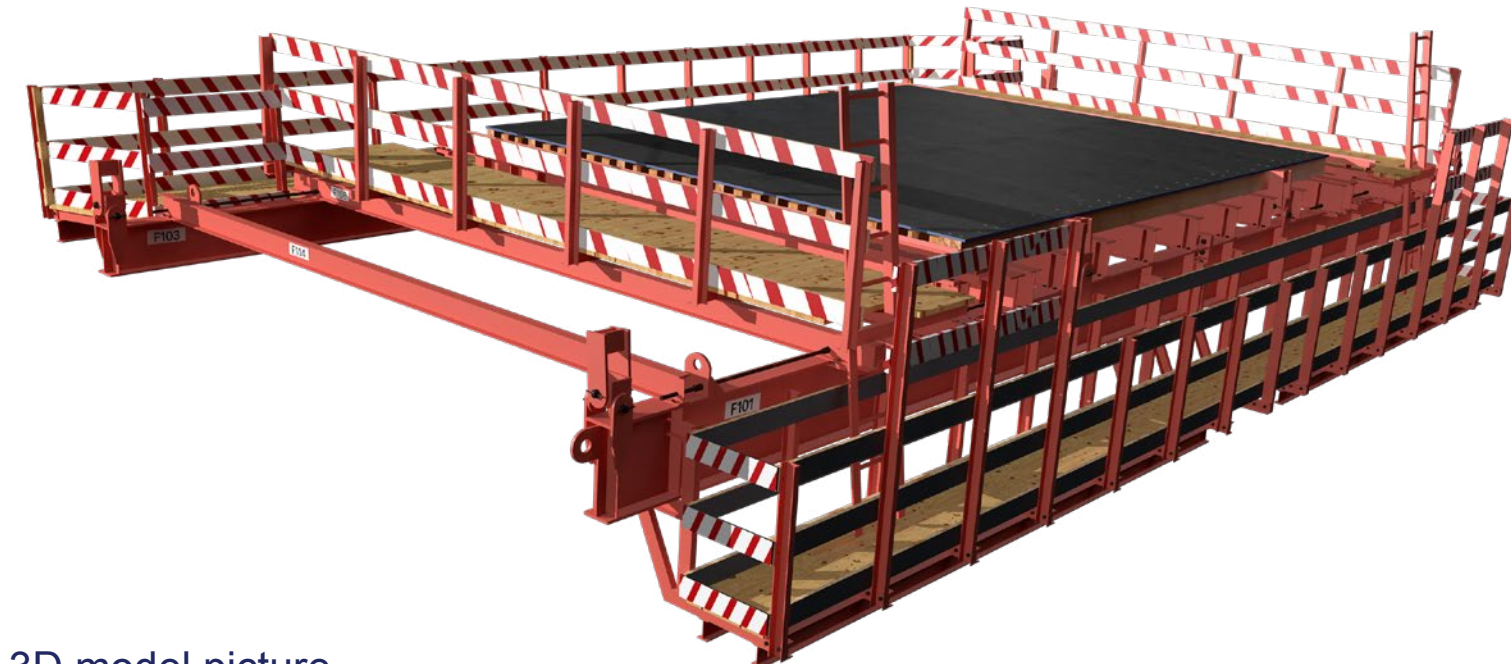

3D model picture



General view



Front winch



Rear winch



Installation of preassembled rebar cage

The Overhead Form Traveller (FT) system can be equipped with a web rebar cage installation device, allowing the panels of this rebar cage preassembled at ground level to be positioned in the formwork.



3 Underslung Form Traveller system

Underslung Form Traveller system

The Underslung Form Traveller solution can be adapted to different types of bridge decks, such as arch bridges and cable-stayed bridges, leaving enough room to assemble the temporary or final cable stays, and allowing easy launchback to the initial assembly position.

Main components:

- | | | |
|---------------------|------------------------|--------------------|
| ① Front anchor | ⑦ Main rail | ⑫ Lower chord |
| ② External formwork | ⑧ Lateral guiding | ⑬ Rear bogie |
| ③ Middle anchor | ⑨ Longitudinal guiding | ⑭ Lateral platform |
| ④ Front bogie | ⑩ Rear anchor | ⑮ Access platform |
| ⑤ C-hook | ⑪ Upper chord | ⑯ Main frame |
| ⑥ Ladder | | |

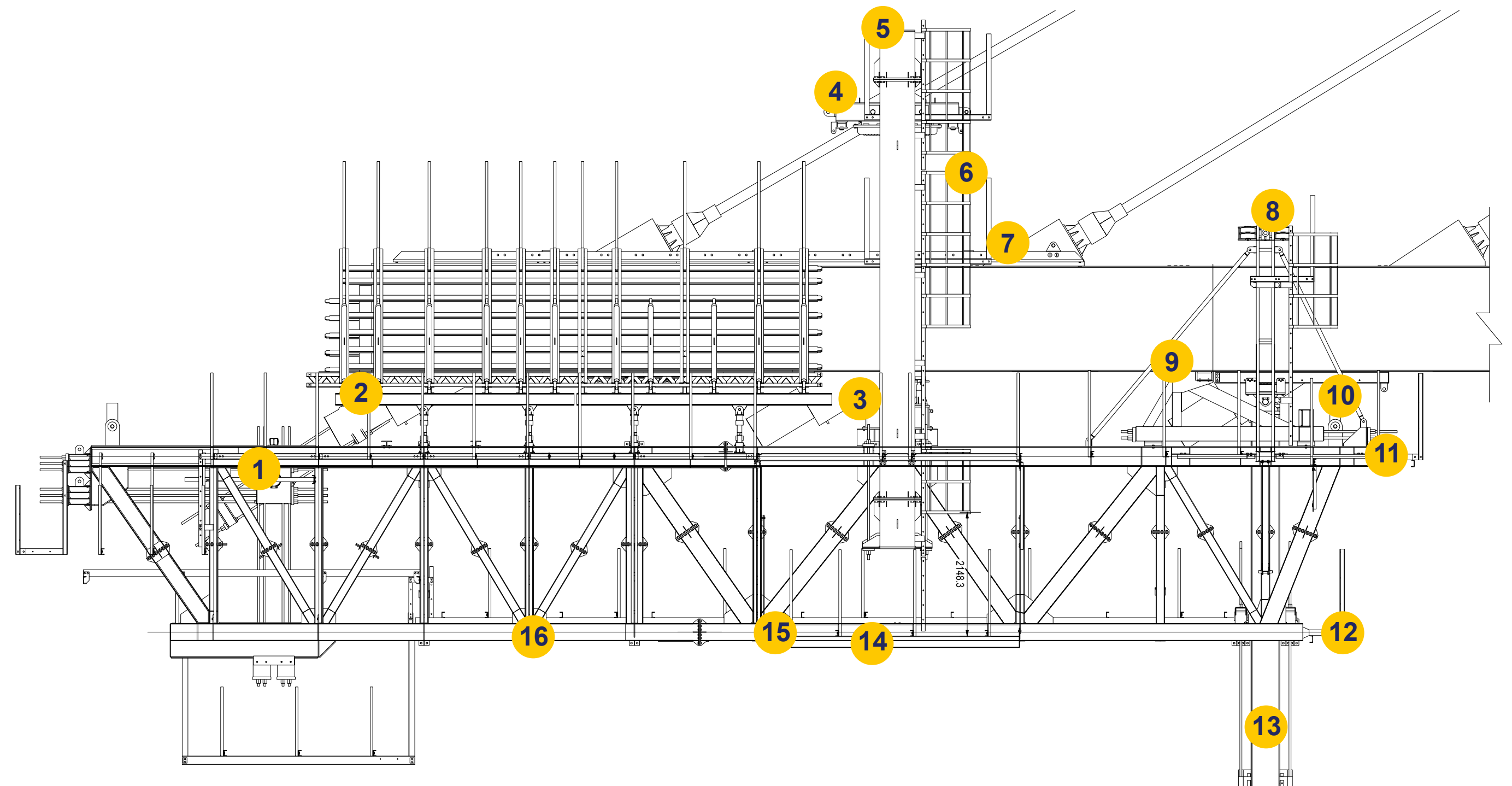

When the rebar cage is preassembled, the Struktur Underslung Form Traveller is the perfect choice.

The external formwork of this type of Form Traveller is supported by the main structure, leaving enough room to install the preassembled rebar cage.



4

Wing Form Traveller system



Wing Form Traveller system

The Wing Form Traveller system is used to cast the deck wings in a second stage.

The Wing Form Traveller's length can be specifically sized to each project. Normally, sections up to 15 metres in length are cast.

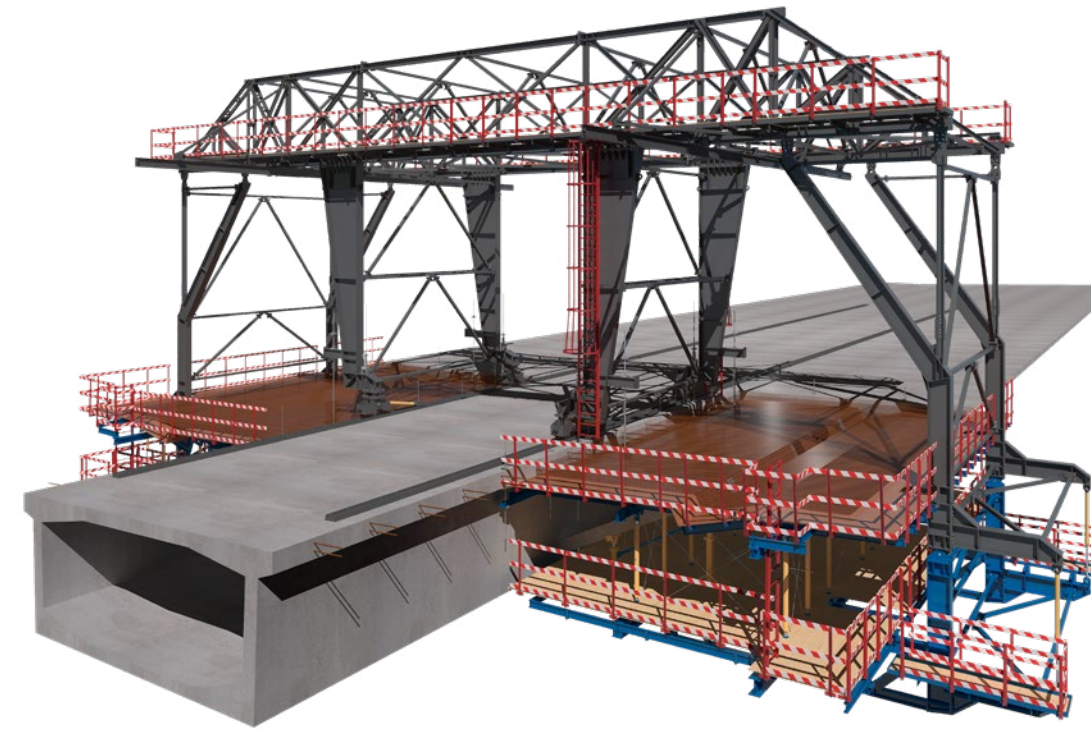
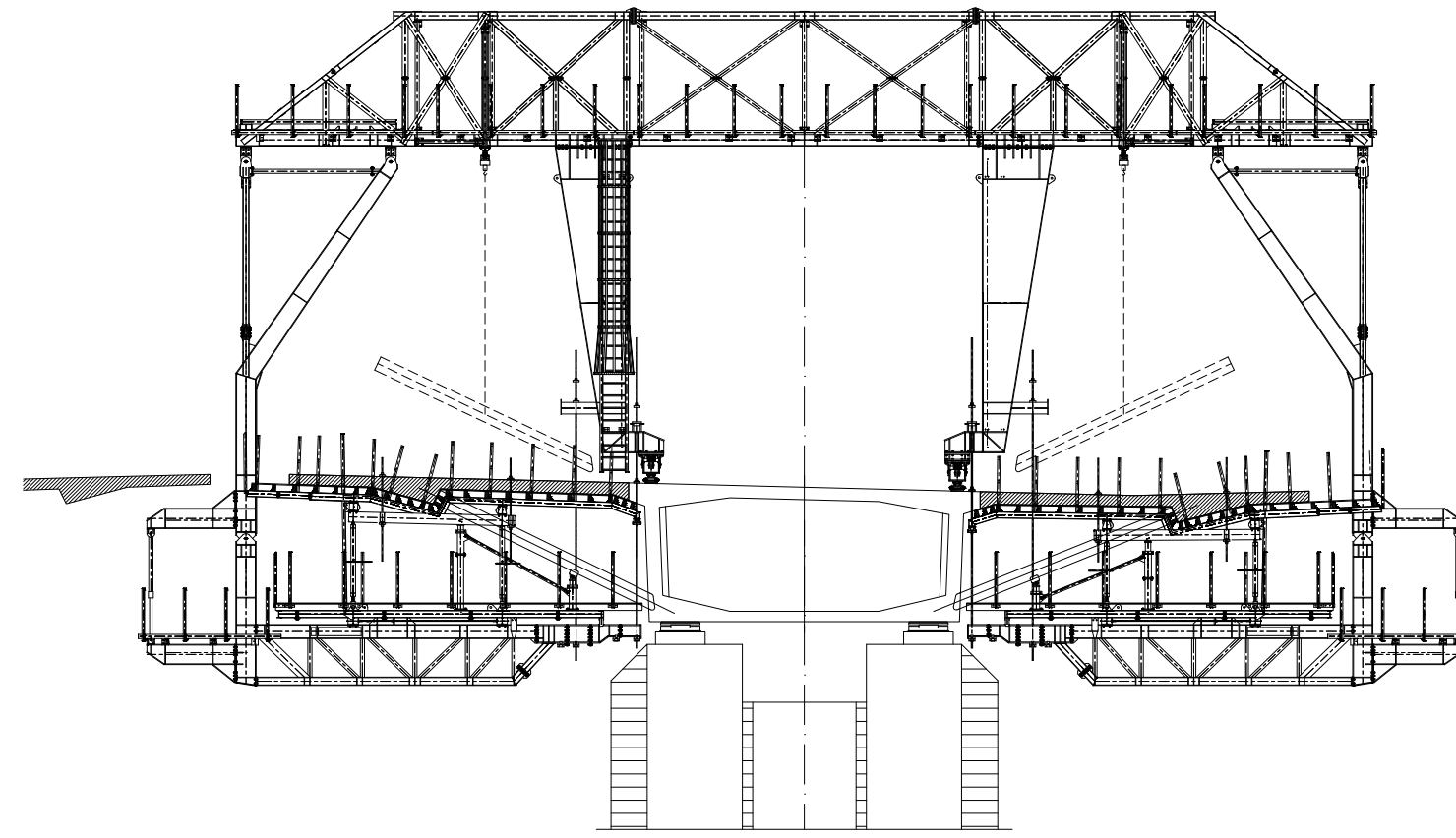

5

Arch Form Traveller system





Arch Form Traveller system

The Arch Form Traveller system is used in casting bridge arches, allowing normally symmetrical sections to be cast from the abutments.

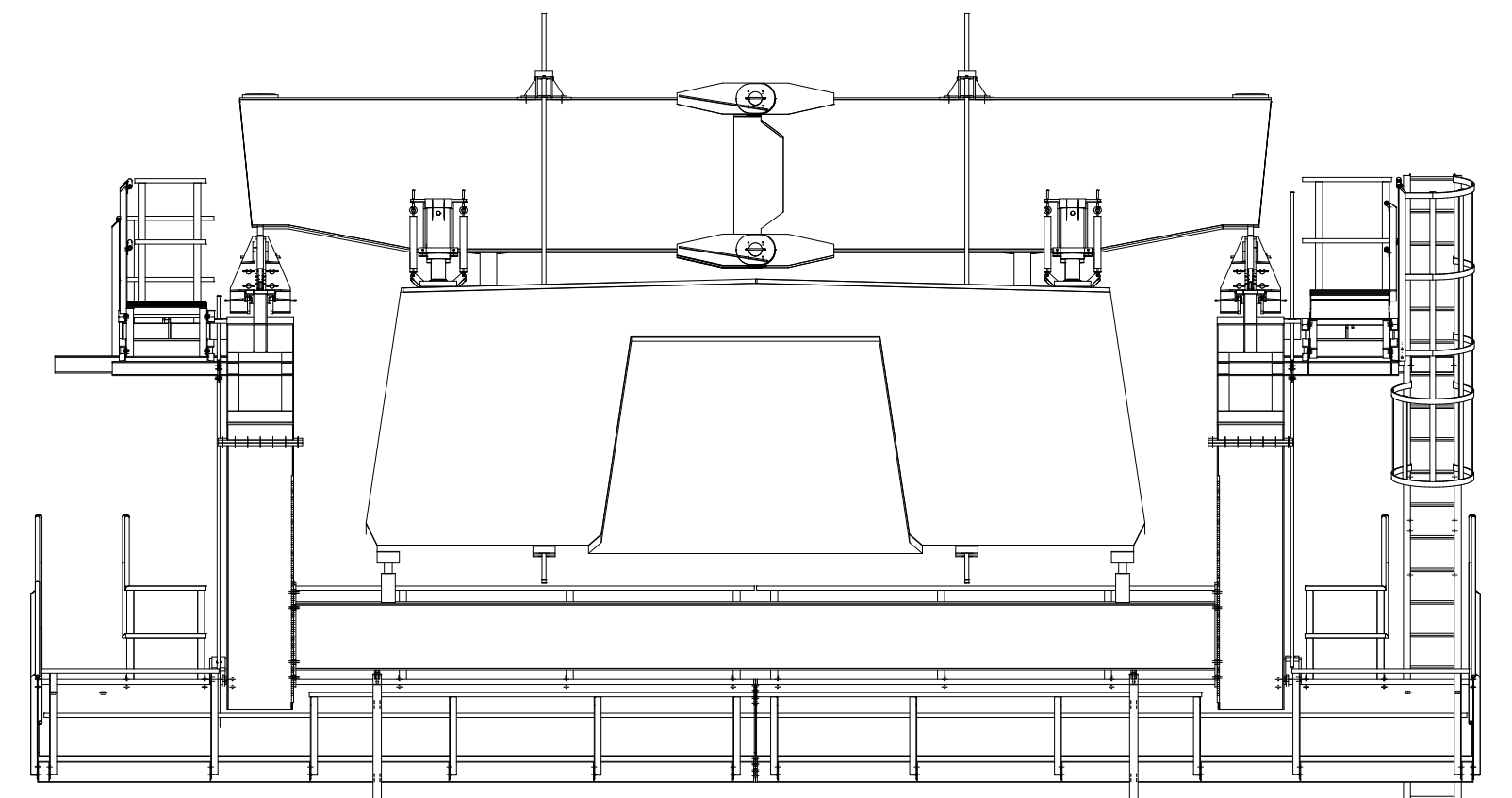

6

Project gallery





Arch Form Traveller - Oparno



Underslung Form Traveller – Batan Kayan, Malaysia



Overhead Form Traveller – Mondego, Portugal



Underslung Form Traveller – Indian River, USA



Overhead Form Traveller – Catumbela, Angola



Overhead Form Traveller – Zenica, Bosnia



Overhead Form Traveller – Crete, Greece



Wing Form Traveller – Wisla, Poland



Overhead Form Traveller – Rimbachtal, Germany



Overhead Form Traveller – Corgo, Portugal

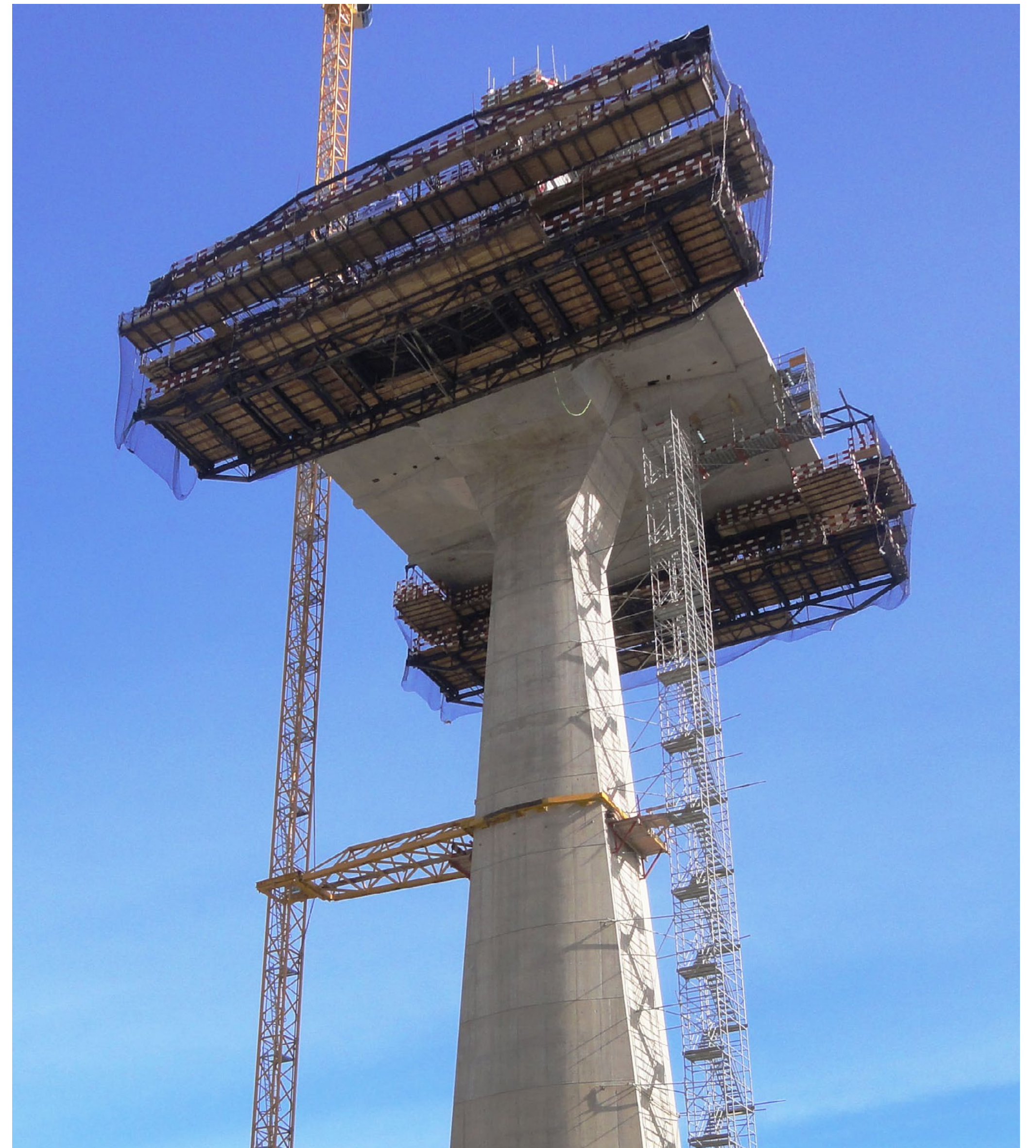

Overhead Form Traveller – Tua, Portugal



Overhead Form Traveller – Constantine, Algeria



Overhead Form Traveller – Bad Liebenwerda, Germany



Overhead Form Traveller – Salamanca, Spain

7 Safety and quality



Safety and quality

Our more than 30 years of experience in designing and supplying bridge-building equipment are leveraged by norms to uphold the high quality, simplicity and user safety of the resulting solutions.

A proper set of work platforms and ladders provides operators with safe access in carrying out all everyday tasks during the segment construction cycle.



The Form Travellers' steel structure is produced in CE-certified steel workshops. Special components such as hydraulic systems, threaded bars and express rollers are manufactured by the world's best suppliers.

8

Services



Our services includes

01

Quotes during tender stage

02

Design, fabrication, delivery and technical assistance

03

Redesign of existing equipment

04

Assembly, operation and dismantling



STRUKTURAS

WE MAKE IT SIMPLE !



Hydrovegen 55,
3936 Porsgrunn,
Norway

Phone: +47 35 96 82 00
office@strukturas.no

www.strukturas.no

